



**EVANS ELECTRONIC VALVE AND
ELECTRONIC TEMPERATURE CONTROL TROUBLESHOOTING GUIDE
for systems equipped with the EVANS electric coolant valve and control
system.**



This guide is intended for use with the EVANS electronic coolant valve shown at left and its control system.

For other electronic coolant control systems, refer to [Cable-less Electronic Valve – 2002 and Prior](#).

For other HVAC system components, diagnoses, and repair, refer back to the [Cable and Rotary Control Systems](#) Menu for the appropriate topic.

NOTICE

Read the entire troubleshooting guide and familiarize yourself with the procedures before attempting any of the procedures described in this document.

VALVE IDENTIFICATION

There are two types of actuators on the valves that Evans supplies as shown in the illustration below. The significant difference in the valves is the arrangement of the terminals in the connector housing on the actuator. Old style valves used from 2002 to 2005 have a distinct “T” pattern as shown on the right and the manufacturer’s logo “Seitz” on the actuator, while newer valves used from 2006 and later have the terminals located in the four corner positions of the connector housing, as seen on the left, and the actuator manufacturer’s logo “CEI” on the cover.

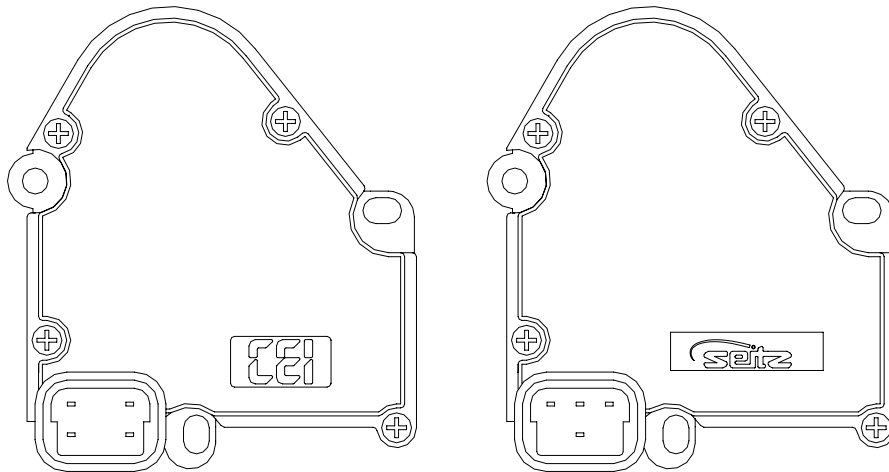

NEW

OLD

Inspect the main harness valve connector and valve pin pattern to ensure the correct valve was previously installed on the vehicle. The connector pattern should have three wires in a straight line for the old style valve (on left below), not a 3 corner or 'L' pattern for the new valve (on right below). If a new style valve has been installed on a vehicle with an older style harness, a jumper needs to be installed between the harness and the valve to correctly orient the terminals for the new style valve. Contact your service parts representative if it is determined a jumper is required and you do not have one.

Evans service parts kit # RV218999 is intended for use to replace an old style valve with a new valve and contains the necessary jumper along with the valve. Service parts kit # RV218967 is intended for systems that have the new style valve and harness and does not contain the jumper harness for older systems.

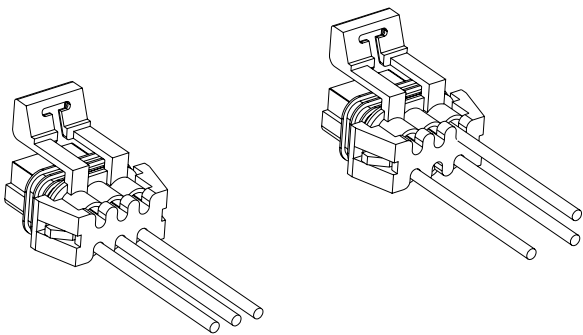

OLD

NEW

When plugging the connector from the harness into the valve connector socket, **be sure to push the connector straight into the socket and do not rock the connector** as it is inserted as this could cause the pins in the connector to become bent or misaligned.

SYSTEMS CHECK

Before attempting to troubleshoot, verify that the HVAC system (other than temperature control) is operating correctly. With the vehicle running, test-operate the system and check the following:

- Blower Motor and 4 operating speeds
 - Mode selector switch and air distribution system
 - A/C system (engine-driven compressor, refrigeration system, etc.).
1. With the vehicle running and the A/C system engaged (Blower turned on, Mode selector set to "MAX A/C", Temperature dial rotated to full cool), clamp off the heater inlet hose to see if the A/C system is cooling properly. Test the A/C performance using the [A/C Systems Operational Check](#) and [Estimated A/C Performance Guidelines](#). Once this has been determined (and corrected if necessary), remove the clamp from the coolant inlet hose.

If a significant loss in cooling capacity in the A/C system occurs when the clamp is removed, shut the vehicle off, and carefully follow the step-by-step directions listed below for troubleshooting the coolant control system. If a problem is found, repair/correct the fault before proceeding to the next step. When troubleshooting electric and/or electronic components, care must be taken to prevent component damage while inspecting, using a test meter, light, etc. If questions or concerns arise during the troubleshooting process, contact Evans Tempcon for telephone assistance **before** proceeding further (1-800-878-7147).

COMPONENT TESTING

1. The temperature control is located in the center of the HVAC system control panel. Rotate the potentiometer knob to verify smooth operation. The knob should rotate freely from the cool stop (blue), to the warm stop (red). Do not force the knob to rotate past the cool or warm stops. Doing so will cause irreparable damage to the potentiometer control. If the knob can be rotated past the internal stop at the full cool and full heat positions, the potentiometer must be replaced before any further valve diagnostics is done.
2. Locate the electronic coolant valve assembly in the heater base unit compartment, near the Evans Heater-Evaporator unit (on the firewall). The electrical connector is located on the top of the actuator housing.
3. Verify that the port on the outlet side of the valve is connected to the inlet tube on the heater coil. A flow direction indicator is located on the side of the valve to help distinguish inlet and outlet ports. Also, the inlet side of the valve is always on the same side as the harness connector. New valves also have tape wrapped around the inlet port that clearly identifies the inlet port (see the illustration at the beginning of this guide). The coolant supply hose from the engine connects to the inlet side of the valve.

NOTE: The electronic coolant valve is a "directional" valve, and must be correctly installed, or it will not function properly. Coolant valves installed with the coolant flow reversed will leak coolant past the valve cylinder resulting in poor A/C performance. Valves that have been installed backwards should be replaced as damage to the seals can occur if the coolant flow has been applied in the wrong direction.

CAUTION

Removal of the coolant valve should be performed when the engine is cold. Attempting to remove the valve from the system when the engine is hot could result in burns and/or serious injury due to extremely hot coolant escaping under pressure. Do not start the engine while the coolant lines are disconnected as the engine will quickly pump the system dry, which could result in damage to the engine.

4. Verify that the heater supply hose (containing the coolant valve) is actually the hose coming from the supply port on the engine. The supply port is usually on, or near the engine thermostat housing. To positively identify the supply line, remove the valve from the coolant lines and place both ends of the lines into a container to capture escaping fluid. Have an assistant "turn over" the engine while you observe the coolant lines. ***The line that discharges coolant when the engine is turned over is the supply line for the HVAC system.***

NOTE: Note this procedure will not be useful for systems with a bypass or "H" fitting. Correct plumbing will have to be checked at "H" fitting in this case. See your vehicle chassis manual for systems with "H" bypass fittings in the coolant lines.

ELECTRICAL TESTING

1. Verify positive electrical connections at the coolant valve. Verify that a new valve has not been installed on an older system without a jumper harness.
 - a. If a new valve has been installed on an older system a jumper harness is required between the main harness and valve.
 - b. If a new valve is installed on newer system, a jumper harness **should not** be used between the valve and main harness.

NOTE: SEE SECTION 1, VALVE IDENTIFICATION FOR MORE INFORMATION REGARDING NEW AND OLD STYLE VALVES.

2. Unplug the wire harness connector from the coolant valve connector. Check the socket terminals for damage. Inspect the pin terminals on the coolant valve connector for damage. If any pins in the valve connector are loose or broken, replace the valve. Refer to the [Electrical System Schematics](#) for correct pin locations and wire colors.

*Note: Some early production Seitz valve actuators have a short four wire lead. Check the leads to insure they match the pin locations on the wire harness connector. The blue wire on the valve lead is for the manufacturer's testing purposes and is not used during normal valve operation. **When replacing this valve, order Evans kit # RV218999.***

TEMPERATURE CONTROL POTENTIOMETER

3. Use a DC voltage test meter and find a good vehicle ground for the negative probe. Do not use the negative connection on the wire harness.
4. Insert the positive probe from the meter into the black wire terminal on the wire harness valve connector. The voltage value should always read 0 VDC because this is the ground connection for the hot water valve.

NOTE: If voltage is detected on this circuit the entire harness should be visually inspected for damage, incomplete or misaligned connections. Do not proceed with testing until this voltage bleed has been resolved.

5. Insert the positive probe from the meter into the red wire terminal of the wire harness valve connector. The voltage value should always read near the vehicle's regulated voltage. If not then you have an issue with the wire harness or fuse.

NOTE: Low system voltage could be the result of numerous causes and will cause the valve to fail to operate. Do not proceed with testing until this voltage issue has been resolved.

6. Insert the positive probe from the meter into the yellow wire terminal of the wire harness valve connector. Rotate the temperature control knob to the far left (BLUE) position. The voltage value should always read near the vehicle's regulated voltage when the potentiometer is in the closed (BLUE) position.
7. Rotate the temperature control knob to the far right and measure the yellow wire connection. The voltage value should always read 0 VDC when the potentiometer is in the open (RED) position.
8. If the proper voltage readings are not measured at either valve position and all other electrical issues have been resolved, then replace the temperature control potentiometer (**Evans replacement part # RV218549**).

ELECTRONIC VALVE

9. If the voltages readings at the valve connector are normal then carefully plug the connector into the valve and then remove the HVAC control panel to access the temperature control potentiometer connector.
10. Remove the connector from the potentiometer and install a jumper wire on the connector from the red wire terminal to the yellow wire terminal. This will apply full vehicle voltage to the valve and force the valve to fully close. Look into the valve coolant inlet to visually verify that the valve is completely closed.
11. Change the jumper from the red wire terminal to the black wire terminal so that the jumper connects the yellow wire terminal to the black wire terminal. This will ground the control wire of the actuator and the valve should be completely open. Visually verify again.

NOTE: By nature of the design of the valve, when the coolant valve gate is fully open, half of the valve port opening appears to be blocked. At no time will the valve port appear to be empty.

12. If the valve does not visually open or close completely then replace it, attach the coolant inlet hose and secure assembly for proper operation.
13. Proceed to SYSTEM VERIFICATION TEST to determine if repair is complete. Keep in mind that if heated coolant has traveled through the heater core prior to these tests then it will take several minutes before the core cools and proper valve operation can be verified. Operating the A/C system for a few minutes will speed up the process of cooling the heater core.

SYSTEM VERIFICATION TEST

1. Attach both coolant hoses to the correct valve ports, reinstall the control panel, and secure the vehicle for operation.
2. Set the Mode Switch (right side of control panel) to "Vent".
3. Rotate the temperature control to full cool (BLUE - far left position).
4. Start the engine and set the engine speed to 1500 rpms if possible. Remember to have the vehicle transmission in neutral gear and the parking brake ON.
5. Measure the Fresh Air inlet temperature and the dash vent air temperature nearest to the unit (passenger side dash louver) and record the values. Repeat these measurements at 5 minute increments until the engine has reached normal operating temperatures.
6. If the inlet and outlet temperature difference does not vary significantly as the engine warms the coolant then the valve can be considered completely closed. If the temperature difference increases significantly then the valve is leaking coolant through the heater core; replace the valve assembly.
7. Rotate the temperature control to full heat; an immediate significant temperature change should occur between the inlet and outlet temperature readings.
8. Rotate the temperature control back to full cool and monitor the temperature differential. The change will be slower, but the outlet temperature should drop to where no significant difference is detected between inlet and outlet temperatures. If the temperature difference does not stabilize then the valve is leaking coolant through the heater core; replace the valve assembly.

9. Once the faulty component has been identified, the new replacement permanently installed, and everything is buttoned back up, perform an actual function test for warm and cool air with the vehicle running. Test A/C performance using the [A/C Systems Operational Check](#) and [Estimated A/C Performance Guidelines](#).

